

SkyNav SKG16 Series Ultra High Sensitivity and Low Power GPS Receiver Module



General Description

The SkyNav SKG16 series is a complete GPS engine module that features super sensitivity, ultra low power and small form factor. The GPS signal is applied to the antenna input of module, and a complete serial data message with position, velocity and time information is presented at the serial interface with NMEA protocol or custom protocol.

It is based on the high performance features of the MediaTek 3327 single-chip architecture, Its -165dBm tracking sensitivity extends positioning coverage into place like urban canyons and dense foliage environment where the GPS was not possible before. The small form factor and low power consumption make the module easy to integrate into portable device like PNDs, mobile phones, cameras and vehicle navigation systems.

Applications

- LBS (Location Based Service)
- PND (Portable Navigation Device)
- Vehicle navigation system
- Mobile phone



Figure 1: SKG16 series Top View

Features

- Ultra high sensitivity: -165dBm
- Extremely fast TTFF (Time To First Fix) at low signal level
- Low power consumption: Typical $45\text{mA}@3.3\text{V}$
- NMEA-0183 compliant protocol or custom protocol
- Operating voltage: 3.0V to 3.6V
- Operating temperature range: -40 to 85°C
- SMD type with stamp holes
- Small form factor: $13.1 \times 15.9 \times 2.7\text{mm}$
- RoHS compliant (Lead-free)

Pin Assignment

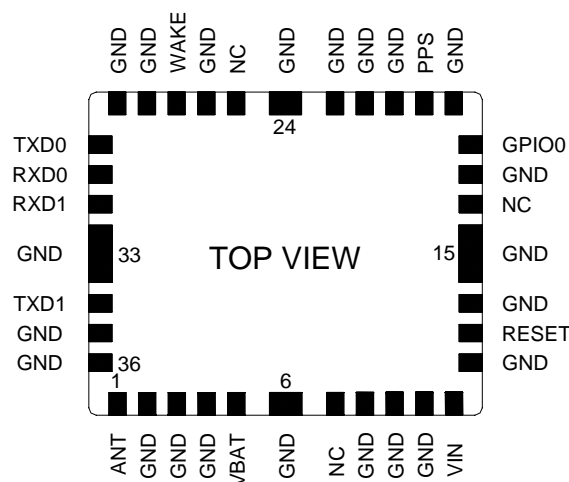

Figure 2: SKG16 Series Pin Package

Performance Specification

Parameter	Specification	
Receiver Type	L1 frequency band, C/A code, 22 Tracking / 66 Acquisition-Channel	
Sensitivity	Tracking	SKG16A -165dBm B -163dBm
	Acquisition	-148dBm
Accuracy	Position	3.0m CEP50 without SA(Typical Open Sky)
	Velocity	0.1m/s without SA
	Timing (PPS)	60ns RMS
Acquisition Time	Cold Start	36s(Typical Open Sky)
	Warm Start	33s
	Hot Start	1s
	Re-Acquisition	<1s
Power Consumption	Tracking	35mA @3.3V Typical
	Acquisition	45mA @3.3V
Navigation Data Update Rate	1Hz	
Operational Limits	Altitude	Max 18,000m
	Velocity	Max 515m/s
	Acceleration	Less than 4g

Interfaces Configuration

Power Supply: Regulated power for the SKG16 series is required. The input voltage Vcc should be 3.0V to 3.6V range, current is no less than 100mA. Suitable decoupling must be provided by external decoupling circuitry(1uF). It can reduce the Noise from power supply and increase power stability.

Antenna: The SKG16 series GPS receiver is designed for supporting the active antenna or passive antenna connected with pin RF_IN. The gain of active antenna should be no more than 25dB. The maximum noise figure should be no more than 1.5dB and output impedance is at 50 Ohm.

UART Ports: The module supports two full duplex serial channels UART. All serial connections are at 2.85V LVTTTL logic levels, if need different voltage levels, use appropriate level shifters. the data format is however fixed: X, N, 8, 1, i.e. X baud rate, no parity, eight data bits and one stop bit, no other data formats are supported, LSB is sent first. The UART0 baud rate is set up 9600bps. The RXD0 & TXD0 recommended to pull

up (10KΩ). It can increase the stability of serial data.

V_BAT: In case of a power failure on pin Vcc, real-time clock and backup RAM are supplied through pin V_BAT. This enables the SKG16 Series GPS Receiver to recover from power failure with either a hot start or a warm start (depending on the duration of Vcc outage). If no Backup Battery is connected, the receiver performs a cold start upon powered up. If you use backup battery, should be adding a bypassing capacitor (10uF) at V_BAT pin. It can reduce noise and increase the stability.

RF_IN: The transmission line must to be control impedance from RF_IN pin to the antenna or antenna connector of your choice. (Impedance 50Ω)

GPIO: The GPIOs functions are for customer used. it recommended to connect to serial resistance(220Ω), if use the GPIO function. If no use GPIO functions, it don't connect anything.

Pin Description

Pin No.	Pin name	I/O	Description	Remark
1	RF_IN	I	GPS Signal Input	50Ω@1.57542GHz
2	GND	G	Ground	GND
3	GND	G	Ground	GND
4	GND	G	Ground	GND
5	VBAT	I	RTC and backup SRAM power (2.0-4.3V)	May be connect to Battery
6	GND	G	Ground	GND
7	NC		No Connect	
8	GND	G	Ground	GND
9	GND	G	Ground	GND
10	GND	G	Ground	GND
11	VIN	I	Module Power Supply	Operating range: 3.0V to 3.6V
12	GND	G	Ground	GND
13	RESET	I	Module Reset (Active Low Status)	Leave open if not used
14	GND	G	Ground	GND
15	GND	G	Ground	GND
16	NC		No Connect	
17	GND	G	Ground	GND
18	GPIO0	I/O	General purpose I/O	Leave Open in not used
19	GND	G	Ground	GND
20	PPS	O	Time pulse Signal (Default 200ms pulse/sec)	Leave Open in not used
21	GND	G	Ground	GND
22	GND	G	Ground	GND
23	GND	G	Ground	GND
24	GND	G	Ground	GND
25	NC		No Connect	
26	GND	G	Ground	GND
27	WAKE	I	WAKE Control Input Pin	Edge triggered(High→Low)
28	GND	G	Ground	GND
29	GND	G	Ground	GND
30	TXD0	O	UART Serial Data Output 0	Fixed NMEA output 9600 GGA、GSA、GSV、RMC
31	RXD0	I	UART Serial Data Input 0	Leave Open in not used
32	RXD1	O	UART Serial Data Output 1	Not Use
33	GND	G	Ground	GND
34	TXD1	I	UART Serial Data Input 1	Not Use
35	GND	G	Ground	GND
36	GND	G	Ground	GND

Electrical Characteristics

Absolute Maximum Rating

Parameter	Symbol	Min	Max	Units
Power Supply				
Power Supply Volt.	VCC	-0.3	3.6	V
Input Pins				
Input Pin Voltage I/O	RST	-0.3	3.6	V
Input Pin Voltage I/O	RX	-0.3	3.6	V
Antenna Bias DC Voltage	RF_IN	-0.3	5.0	V
Backup Battery	V_BAT	-0.3	3.6	V
Environment				
Storage Temperature	Tstg	-40	125	°C
Peak Reflow Soldering Temperature <10s	Tpeak		260	°C
Humidity			95	%

Note: Absolute maximum ratings are stress ratings only, and functional operation at the maxims is not guaranteed. Stress beyond the limits specified in this table may affect device reliability or cause permanent damage to the device. For functional operating conditions, refer to the operating conditions tables as follow.

Recommended Operating Condition

Parameter	Symbol	Condition	Min	Typ	Max	Units
Power supply voltage	Vcc		3.0	3.3	3.6	V
Power supply voltage ripple	Vcc_PP	Vcc=3.0V			30	mV
Consumption current	Icc	Vcc=3.0V		45	50	mA
RTC LDO input Supply Voltage	VBAT		2.0	2.8	3.6	V
Input high voltage	V _{IH}		2.0		3.6	V
Input low voltage	V _{IL}		-0.3		0.8	V
Output high voltage	V _{OH}		2.4		3.1	V
Output low voltage	V _{OL}		-0.3		0.4	V
Operating temperature	Topr		-40		85	°C

Ordering Information

SKG16A: ROM / External LNA

SKG16B: ROM / Internal LNA

Mechanical Specification

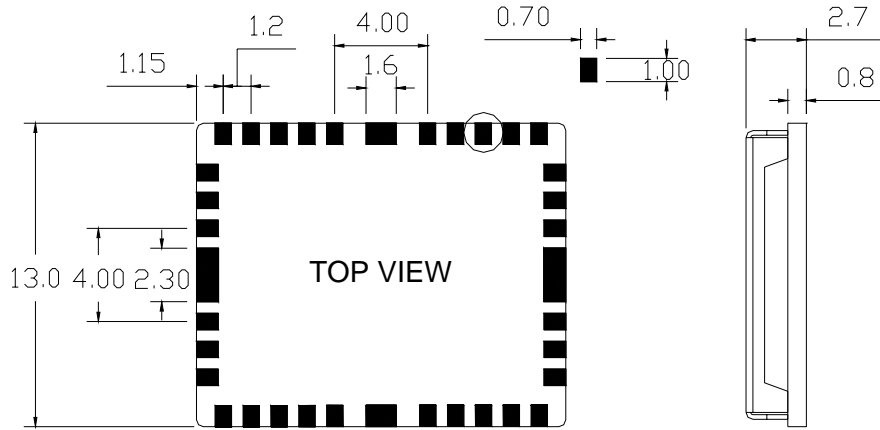

UNIT: mm

Figure 3: SKG16 Series Dimensions

Packaging Specification

SKG16 Series modules are shipped in tray and with 84 units per tray. Each tray is 'dry' package.

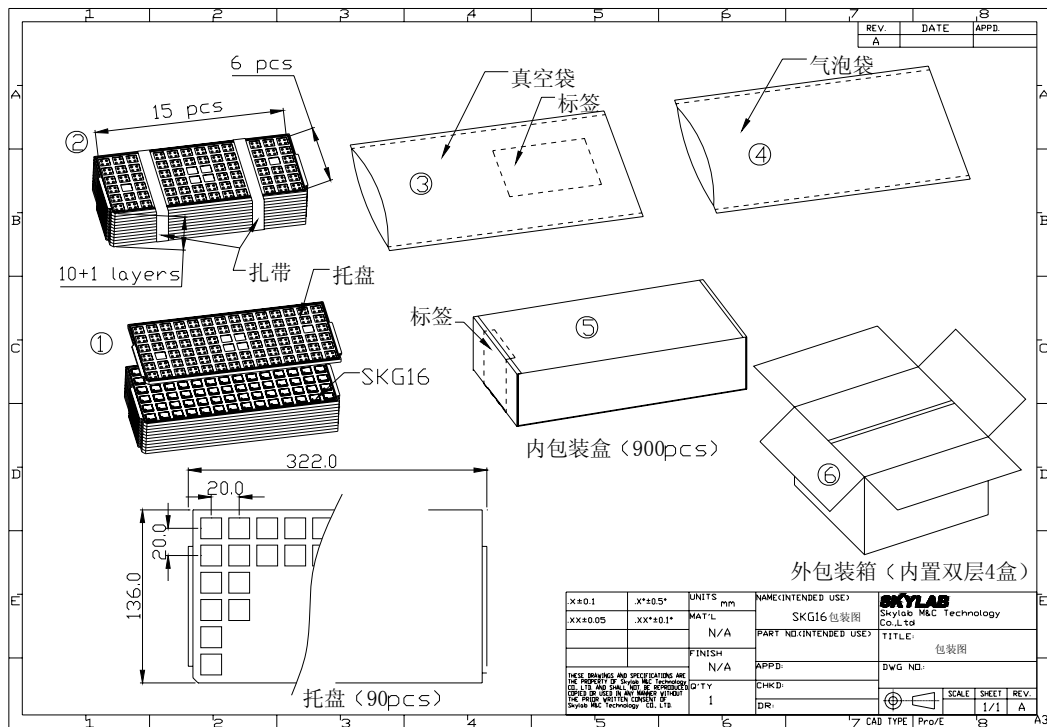

Figure 4: SKG16 Series Packaging

Manufacturing Process Recommendations

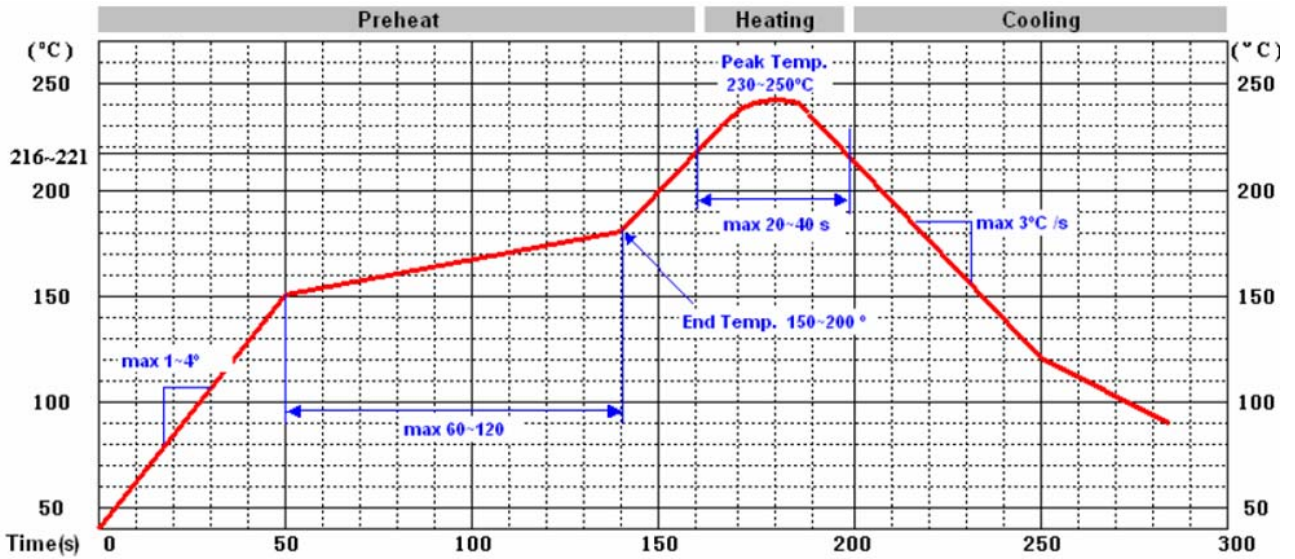
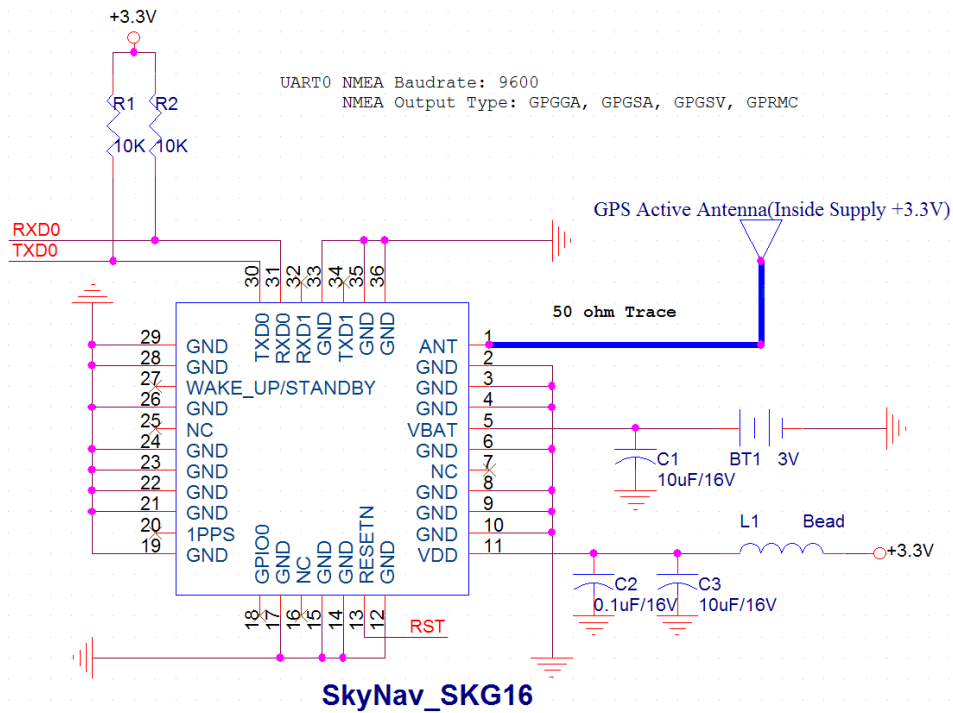

Figure 5: SKG16 Series Typical Leadfree Soldering Profile

Note: The final soldering temperature chosen at the factory depends on additional external factors like choice of soldering paste, size, thickness and properties of the baseboard, etc. Exceeding the maximum soldering temperature in the recommended soldering profile may permanently damage the module.

Reference design schematic



Software Protocol

NMEA 0183 Protocol

The NMEA protocol is an ASCII-based protocol, Records start with a \$ and with carriage return/line feed. GPS specific messages all start with \$GPxxx where xxx is a three-letter identifier of the message data that follows. NMEA messages have a checksum, which

allows detection of corrupted data transfers.

The SkyNav SKG16 series supports the following NMEA-0183 messages: GGA, GLL, GSA, GSV, RMC, VTG, ZDA. Default output GGA, GSA, GSV, RMC and default baud rate is set up 9600bps.

Table 1: NMEA-0183 Output Messages

NMEA Record	DESCRIPTION
GGA	Global positioning system fixed data
GLL	Geographic position—latitude/longitude
GSA	GNSS DOP and active satellites
GSV	GNSS satellites in view
RMC	Recommended minimum specific GNSS data
VTG	Course over ground and ground speed
ZDA	Time and Date

GGA-Global Positioning System Fixed Data

Table 2 contains the values of the following example:

\$GPGGA, 083559.00,3723.2475,N, 12158.3416,W, 1,07,1.0,9.0,M, ,M, ,0000*18

Table 2: GGA Data Format

Name	Example	Units	Description
Message ID	\$GPGGA		GGA protocol header
UTC Time	083559.00		hhmmss.sss
Latitude	3723.2475		ddmm.mmmm
N/S indicator	N		N=north or S=south
Longitude	12158.3416		ddmm.mmmm
E/W Indicator	W		E=east or W=west
Position Fix Indicator	1		See Table 2-1
Satellites Used	07		Range 00 to 12
HDOP	1.0		Horizontal Dilution of Precision
MSL Altitude	9.0	meters	Altitude above mean seal level
Units	M	meters	
Geoids Separation		meters	Separation from Geoids can be bank
Units	M	meters	
Age of Diff.Corr.		second	Null fields when DGPS is not Used
Diff.Ref.Station ID	0000		Null fields when DGPS is not Used

Checksum	*18		
<CR> <LF>			End of message termination(ASCII 13, ASCII 10)

Table 2-1: Position Fix Indicators

Value	Description
0	Fix not available or invalid
1	GPS SPS Mode, fix valid
2	Differential GPS, SPS Mode, fix valid
3	GPS PPS Mode, fix valid

GLL-Geographic Position – Latitude/Longitude

Table 3 contains the values of the following example:
 \$GPGLL , 3723.2475, N,12158.3416, W, 083559.00, A*2C.

Table 3: GLL Data Format

Name	Example	Units	Description
Message ID	\$GPGLL		GLL protocol header
Latitude	3723.2475		Dmmm.mmmm
N/S Indicator	N		N=north or S=south
Longitude	12158.3416		Ddmm.mmmm
E/W Indicator	W		E=east or W=west
UTC Time	083559.00		Hhmmss.sss
Status	A		A=data valid or V=data not valid
Checksum	*2C		
<CR> <LF>			End of message termination(ASCII 13, ASCII 10)

GSA-GNSS DOP and Active Satellites

Table 4 contains the values of the following example:
 \$GPGSA , A, 3, 07, 02, 26,27, 09, 04,15, , , , , , 1.8,1.0,1.5*33.

Table 4: GSA Data Format

Name	Example	Units	Description
Message	\$GPGSA		GSA protocol header
Mode 1	A		See Table 4-2
Mode 2	3		See Table 4-1
Satellite Used	07		Sv on Channel 1
Satellite Used	02		Sv on Channel 2
...
Satellite Used			Sv on Channel 12
PDOP	1.8		Position Dilution of Precision
HDOP	1.0		Horizontal Dilution of Precision

VDOP	1.5		Vertical Dilution of Precision
Checksum	*33		
<CR> <LF>			End of message termination(ASCII 13, ASCII 10)

Table 4-1: Mode 1

Value	Description
1	Fix not available
2	2D
3	3D

Table 4-2: Mode 2

Value	Description
M	Manual-forced to operate in 2D or 3D mode
A	Automatic-allowed to automatically switch 2D/3D

GSV-GNSS Satellites in View

Table 5 contains the values of the following example:

\$GPGSV , 2, 1, 07, 07, 79, 048, 42, 02, 51,062, 43, 26, 36,256, 42, 27, 27, 138,42*71

\$GPGSV , 2, 2, 07, 09, 23,313, 42, 04, 19, 159, 41, 15,12,041, 42*41.

Table 5: GGA Data Format

Name	Example	Units	Description
Message ID	\$GPGSV		GSV protocol header
Number of Message	2		Range 1 to 3
Message Number	1		Range 1 to 3
Satellites in View	07		
Satellite ID	07		Channel 1(Range 1 to 32)
Elevation	79	degrees	Channel 1(Maximum 90)
Azinmuth	048	degrees	Channel 1(True, Range 0 to 359)
SNR(C/NO)	42	dBHz	Range 0 to 99,null when not tracking
...			...
Satellite ID	27		Channel 4(Range 1 to 32)
Elevation	27	degrees	Channel 4(Maximum 90)
Azimuth	138	degrees	Channel 4(True, Range 0 to 359)
SNR(C/NO)	42	dBHz	Range 0 to 99, null when not tracking
Checksum	*71		
<CR> <LF>			End of message termination(ASCII 13, ASCII 10)

Depending on the number of satellites tracked multiple messages of GSV data may be required.

RMC-Recommended Minimum Specific GNSS Data

Table 6 contains the values of the following example:

\$GPRMC, 083559.00, A, 3723.2475, N, 12158.3416, W, 0.13, 309.62, 120598, , *10

Table 6: RMC Data Format

Name	Example	Units	Description
Message ID	\$GPRMC		RMC protocol header
UTC Time	083559.00		hhmmss.sss
Status	A		A=data valid or V=data not valid
Latitude	3723.2475		ddmm.mmmm
N/S Indicator	N		N=north or S=south
Longitude	12158.3416		Ddmm.mmmm
E/W Indicator	W		E=east or W=west
Speed Over Ground	0.13	Knots	
Course Over Ground	309.62	Degrees	True
Date	120598		Dummy
Magnetic variation		Degrees	Not used
E/W indicator			Not used
Mode			Only NMEA0183 version 3.00 output
Checksum	*10	hexadecimal	
<CR> <LF>			End of message termination(ASCII 13, ASCII 10)

VTG-Course Over Ground and Ground Speed

Table 7 contains the values of the following example:

\$GPVTG, 309.62, T, ,M, 0.13, N, 0.2, K*6E

Table 7: VTG Data Format

Name	Example	Units	Description
Message ID	\$GPVTG		VTG protocol header
Course	309.62	Degrees	Measured heading
Reference	T		True
Course		Degrees	Measured heading
Reference	M		Magnetic
Speed	0.13	Knots	Measured horizontal speed
Units	N		Knots
Speed	0.2	Km/hr	Measured horizontal speed
Units	K		Kilometer per hour
Checksum	*6E		
<CR> <LF>			End of message termination

ZDA-Date and Time

Table 8 contains the values of the following example:

\$GPZDA, 082710.00,04,07,2002,00,00*60

Name	Example	Units	Description
Message ID	\$GPZDA		ZDA protocol header
UTC Time	082710.00		hhmmss.sss
Day	04		UTC time: day (01 ... 31)
Month	07		UTC time: month (01 ... 12)
Year	2002		UTC time: year (4 digit year)
local zone hours	00		Not supported (fixed to 00)
local zone minutes	00		Not supported (fixed to 00)
Checksum	*60		
<CR> <LF>			End of message termination

How to Reach Us:

Skylab M&C Technology Co., Ltd.

Address: Room.801, Bldg.211, Terra Industrial Park, Futian District, Shenzhen

Phone: 86-755 8340 8210 (Sales Support)

Phone: 86-755 8340 8130 (Technical Support)

Fax: 86-755-8340 8560

E-Mail: sales@skylab.com.cn

©Copyright 2008 SkyLab M&C Co., Ltd, All Right Reserved

The information contained herein is subject to change without notice.