

SkyNav GM25

Ultra High Sensitivity and Low Power GPS Receiver Module



General Description

The SkyNav GM25 is a complete GPS engine module that features super sensitivity, ultra low power and small form factor. The GPS signal is applied to the antenna input of module, and a complete serial data message with position, velocity and time information is presented at the serial interface with NMEA protocol or custom protocol.

It is based on the high performance features of the Atheros uN3010(AR1511) single-chip architecture, Atheros newest chipset technology. Its -160dBm tracking sensitivity extends positioning coverage into place like urban canyons and dense foliage environment where the GPS was not possible before. The small form factor and low power consumption make the module easy to integrate into portable device like PNDs, mobile phones, cameras and vehicle navigation systems.



Figure 1: GM25 Top View

Features

- Ultra high sensitivity: -160dBm
- Extremely fast TTFF at low signal level
- Built in high gain LNA
- Low power consumption: Typical $35\text{mA}@3.0\text{V}$
- NMEA-0183 compliant protocol or custom protocol
- Operating voltage: 2.85V to 3.3V
- Operating temperature range: -40 to 85°C
- SMD type with stamp holes
- Small form factor: $25\times 25\times 2.9\text{mm}$
- RoHS compliant (Lead-free)

Applications

- LBS (Location Based Service)
- PND (Portable Navigation Device)
- Vehicle navigation system
- Mobile phone

Pin Assignment

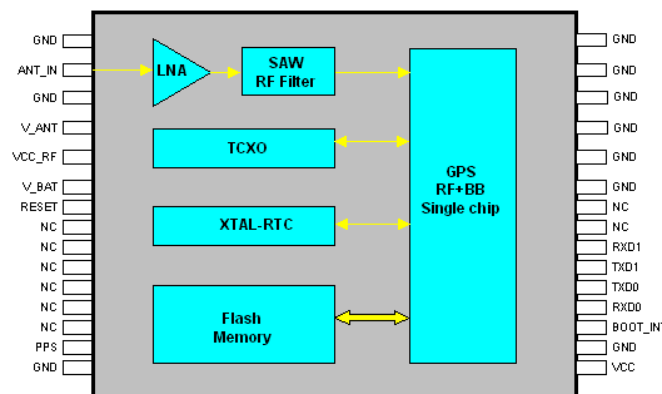

Figure 2: GM25 Pin Package

Performance Specification

Parameter	Specification	
Receiver Type	L1 frequency band, C/A code, 20-channels	
Sensitivity	Tracking	-160dBm
	Acquisition	-144dBm
Accuracy	Position	3.0m CEP50 without SA(Typical Open Sky)
	Velocity	0.1m/s without SA
	Timing (PPS)	60ns RMS
Acquisition Time	Cold Start	36s(Typical Open Sky)
	Warm Start	30s
	Hot Start	2s
	Re-Acquisition	<1s
Power Consumption	Tracking	35mA @3V Vcc(Typical)
	Acquisition	35mA
Navigation Data Update Rate	1Hz	
Operational Limits	Altitude	Max 18,000m
	Velocity	Max 515m/s
	Acceleration	Less than 4g

Interfaces Configuration

Power Supply: Regulated power for the GM25 is required. The input voltage Vcc should be 3.0V \pm 10%, maximum, current is no less than 100mA. Suitable decoupling must be provided by external decoupling circuitry.

Antenna: The GM25 GPS receiver is designed for supporting the active antenna or passive antenna connected with pin RF_IN. The gain of active antenna should be no more than 20dB. The maximum noise figure should be no more than 1.5dB and output impedance is at 50 Ohm.

UART Ports: The module supports two full duplex serial channels UART0 and UART1. All serial connections are at 3V CMOS logic levels, if need different voltage levels, use appropriate level shifters. The baud rate of both serial ports are fully programmable, the data format is however fixed: X, N, 8, 1, i.e. X baud rate, no parity, eight data bits and one stop bit, no other data formats are supported, LSB is sent first. The

modules default baud rate is set up 4800bps, however, the user can change the default baud rate to any value from 4800 bps to 115kbps. UART0 is used e.g. for booting and NMEA interface. UART1 can be utilized for UBP protocol.

Boot Mode Select: The pin Boot is used to set the boot mode of the GM25 GPS Receiver. By default the receiver will boot in normal GPS mode. If there are corrupted data in FLASH, it may be necessary to boot the receiver in test mode by pulling Boot pin high during a power cycle or hardware reset to update the firmware.

Backup Battery Power: In case of a power failure on pin Vcc, real-time clock and backup RAM are supplied through pin V_BAT. This enables the GM25 GPS Receiver to recover from power failure with either a hot start or a warm start (depending on the duration of Vcc outage). If no Backup Battery is connected, the receiver performs a cold start upon powered up.

Pin Description

Pin No.	Pin name	I/O	Description	Remark
1	Vcc	I	Module Power Supply	
2	GND	G	Ground	
3	BOOT_INT	I	Boot Mode	Leave Open if not used
4	RXD0	I	UART Serial Data Input 0	Pull up (10KΩ) if not used
5	TXD0	O	UART Serial Data Output 0	Leave Open in not used
6	TXD1	O	UART Serial Data Output 1	Not Open
7	RXD1	I	UART Serial Data Input 1	Not Open
8	NC		No Connection	
9	NC		No Connection	
10	GND	G	Ground	
11	GND	G	Ground	
12	GND	G	Ground	
13	GND	G	Ground	
14	GND	G	Ground	
15	GND	G	Ground	
16	GND	G	Ground	
17	ANT_IN	I	Antenna Input	
18	GND	G	Ground	
19	V_ANT	I	Active Antenna External Voltage Supply	
20	Vcc_RF	O	Voltage Output for Active Antenna	
21	V_BAT	I	RTC Battery Input	Leave Open in not used
22	Reset	I	Module Reset	Leave Open in not used
23~28	NC		No Connection	Leave Open in not used
29	PPS	O	Time Pulse (1PPS)	Leave Open in not used
30	GND	G	Ground	Leave Open in not used

Electrical Characteristics

Absolute Maximum Rating

Parameter	Symbol	Min	Max	Units
Power Supply				
Power Supply Volt.	Vcc	-0.3	3.6	V
Input Pins				
Input Pin Voltage I/O	Reset	-0.3	3.6	V
Input Pin Voltage I/O	RX0, RX1	-0.3	3.6	V
Input Pin Voltage I/O	BOOT	-0.3	3.6	V
Antenna Bias DC Voltage	V_ANT	-0.3	5.0	V
Backup Battery	V_BAT	2.0	5.0	V

Environment				
Storage Temperature	Tstg	-40	125	°C
Peak Reflow Soldering Temperature <10s	Tpeak		260	°C
Humidity			95	%

Note: Absolute maximum ratings are stress ratings only, and functional operation at the maxims is not guaranteed. Stress beyond the limits specified in this table may affect device reliability or cause permanent damage to the device. For functional operating conditions, refer to the operating conditions tables as follow.

Operating Conditions

Parameter	Symbol	Condition	Min	Typ	Max	Units
Power supply voltage	Vcc		3.0		3.3	V
Power supply voltage ripple	Vcc_PP	Vcc=3.0V			30	mV
Consumption current	Icc	Vcc=3.0V		35	40	mA
Input high voltage	V _{IH}		0.7xVcc		Vcc+1.0	V
Input low voltage	V _{IL}		-0.3		0.3xVcc	V
Output high voltage	V _{OH}		0.8xVcc		Vcc	V
Output low voltage	V _{OL}		0		0.2xVcc	V
Operating temperature	Topr		-40		85	°C

Mechanical Specification

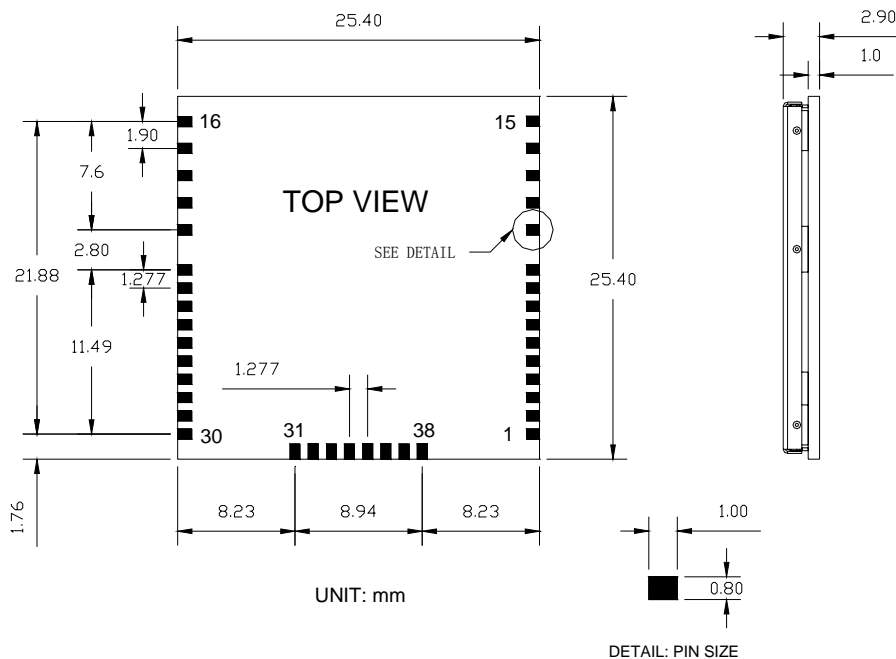

Figure 3: GM25 Dimensions

Packaging Specification

GM25 modules are shipped in tray and with 40 units per tray. Each tray is 'dry' package.

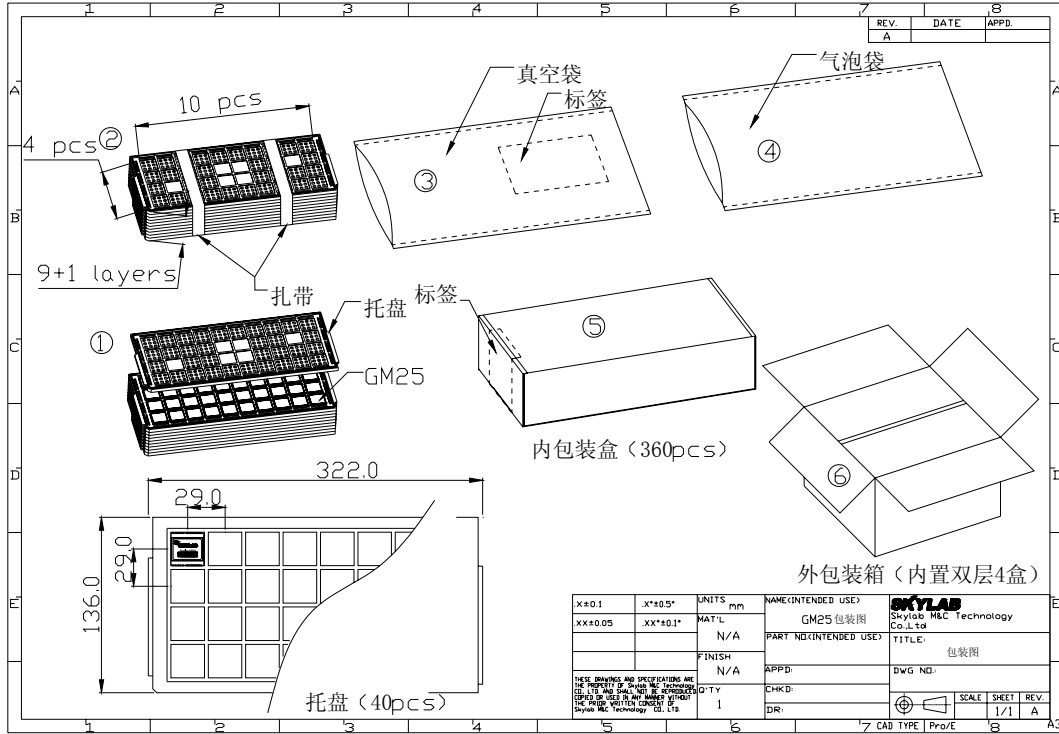

Figure 4: GM25 Packaging

Manufacturing Process Recommendations

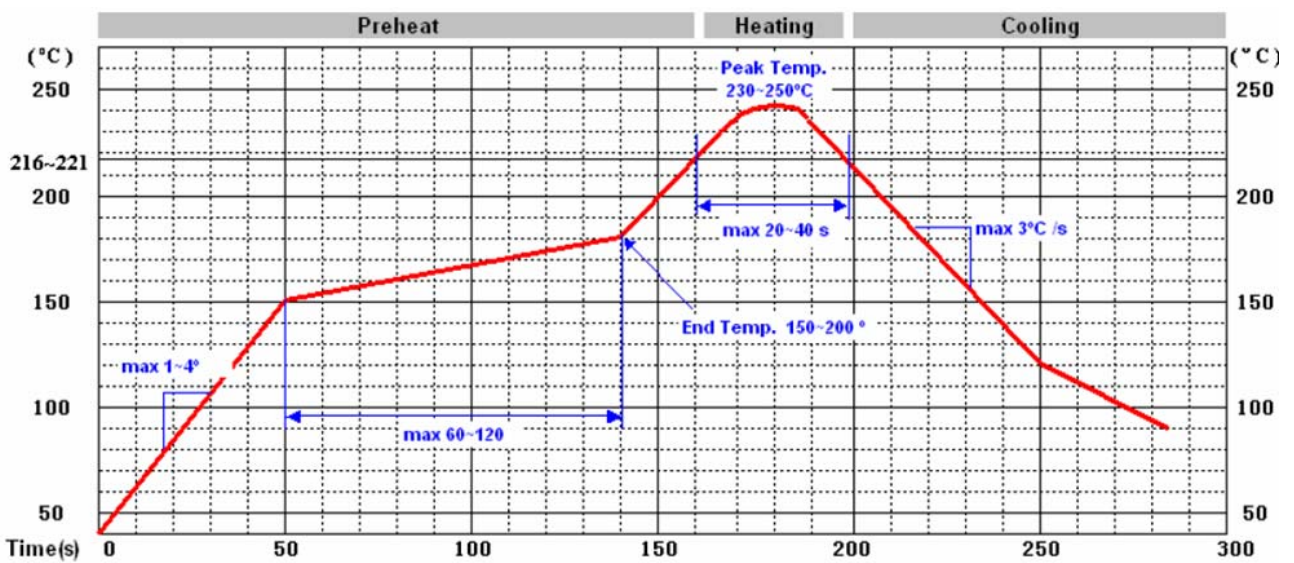

Figure 5: GM25 Typical Leadfree Soldering Profile

Note: The final soldering temperature chosen at the factory depends on additional external factors like choice of soldering paste, size, thickness and properties of the baseboard, etc. Exceeding the maximum soldering temperature in the recommended soldering profile may permanently damage the module.

Reference design schematic

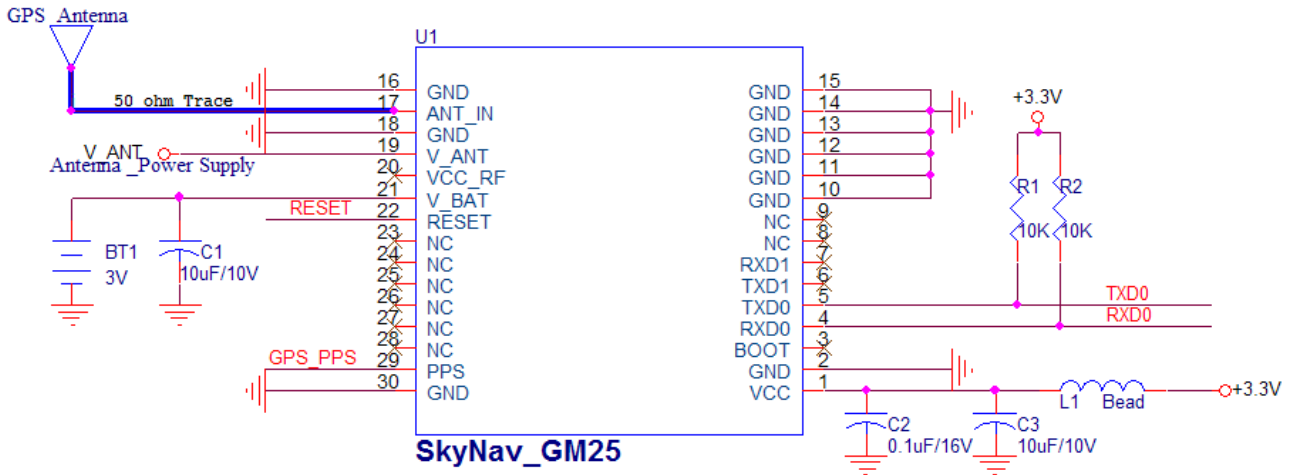

Figure 6: GM25 Typical Reference design schematic

Software Protocol

NMEA 0183 Protocol

The NMEA protocol is an ASCII-based protocol, Records start with a \$ and with carriage return/line feed. GPS specific messages all start with \$GPxxx where xxx is a three-letter identifier of the message data that follows. NMEA messages have a checksum, which allows detection of corrupted data transfers.

The SkyNav GM25 module supports the following NMEA-0183 messages: GGA, GLL, GSA, GSV, RMC VTG, ZDA and DTM. The module default NMEA-0183 output is set up GGA,GSA,GSV,RMC and default baud rate is set up 4800bps.

Table 1: NMEA-0183 Output Messages

NMEA Record	DESCRIPTION
GGA	Global positioning system fixed data
GLL	Geographic position—latitude/longitude
GSA	GNSS DOP and active satellites
GSV	GNSS satellites in view
RMC	Recommended minimum specific GNSS data
VTG	Course over ground and ground speed

GGA-Global Positioning System Fixed Data

Table 2 contains the values of the following example:

\$GPGGA, 161229.487,3723.2475,N, 12158.3416,W, 1,07,1.0,9.0,M.0000*18

Table 2: GGA Data Format

Name	Example	Units	Description
Message ID	\$GPGGA		GGA protocol header
UTC Position	161229.487		hhmmss.sss
Latitude	3723.2457		ddmm.mmmm
N/S indicator	N		N=north or S=south
Longitude	12158.3416		ddmm.mmmm
E/W Indicator	W		E=east or W=west
Position Fix Indicator	1		See Table 2-1
Satellites Used	07		Range 0 to 12
HDOP	1.0		Horizontal Dilution of Precision
MSL Altitude	9.0	meters	
Units	M	meters	
Geoids Separation		meters	
Units	M	meters	
Age of Diff.Corr.		second	Null fields when DGPS is not Used
Diff.Ref.Station ID	0000		
Checksum	*18		
<CR> <LF>			End of message termination

Table 2-1: Position Fix Indicators

Value	Description
0	Fix not available or invalid
1	GPS SPS Mode, fix valid
2	Differential GPS, SPS Mode, fix valid
3	GPS PPS Mode, fix valid

GLL-Geographic Position – Latitude/Longitude

Table 3 contains the values of the following example:

\$GPGLL , 3723.2475, N,12158.3416, W,161229.487, A*2C.

Table 3: GLL Data Format

Name	Example	Units	Description
Message ID	\$GPGLL		GLL protocol header
Latitude	3723.2475		Ddmm.mmmm
N/S Indicator	N		N=north or S=south
Longitude	12158.3416		Ddmm.mmmm
E/W Indicator	W		E=east or W=west
UTC Position	161229.487		Hhmmss.sss
Status	A		A=data valid or V=data not valid
Checksum	*2C		

<CR> <LF>			End of message termination
-----------	--	--	----------------------------

GSA-GNSS DOP and Active Satellites

Table 4 contains the values of the following example:

\$GPGSA , A, 3, 07, 02, 26,27, 09, 04,15, , , , , 1.8,1.0,1.5*33.

Table 4: GSA Data Format

Name	Example	Units	Description
Message	\$GPGSA		GSA protocol header
Mode 1	A		See Table 4-2
Mode 2	3		See Table 4-1
Satellite Used	07		Sv on Channel 1
Satellite Used	02		Sv on Channel 2
...
Satellite Used			Sv on Channel 12
PDOP	1.8		Position Dilution of Precision
HDOP	1.0		Horizontal Dilution of Precision
VDOP	1.5		Vertical Dilution of Precision
Checksum	*33		
<CR> <LF>			End of message termination

Table 4-1: Mode 1

Value	Description
1	Fix not available
2	2D
3	3D

Table 4-2: Mode 2

Value	Description
M	Manual-forced to operate in 2D or 3D mode
A	Automatic-allowed to automatically switch 2D/3D

GSV-GNSS Satellites in View

Table 5 contains the values of the following example:

\$GPGSV , 2, 1, 07, 07, 79,048, 42, 02, 51,062, 43, 26, 36,256, 42, 27, 27, 138,42*71

\$GPGSV , 2, 2, 07, 09, 23,313, 42, 04, 19, 159, 41, 15,12,041, 42*41.

Table 5: GGA Data Format

Name	Example	Units	Description
Message ID	\$GPGSV		GSV protocol header
Number of Message	2		Range 1 to 3
Message Number	1		Range 1 to 3
Satellites in View	07		

Satellite ID	07		Channel 1(Range 1 to 32)
Elevation	79	degrees	Channel 1(Maximum 90)
Azinmuth	048	degrees	Channel 1(True, Range 0 to 359)
SNR(C/NO)	42	dBHz	Range 0 to 99,null when not tracking
...			...
Satellite ID	27		Channel 4(Range 1 to 32)
Elevation	27	degrees	Channel 4(Maximum 90)
Azimuth	138	degrees	Channel 4(True, Range 0 to 359)
SNR(C/NO)	42	dBHz	Range 0 to 99, null when not tracking
Checksum	*71		
<CR> <LF>			End of message termination

Depending on the number of satellites tracked multiple messages of GSV data may be required.

RMC-Recommended Minimum Specific GNSS Data

Table 6 contains the values of the following example:

\$GPRMC, 161229.487, A, 3723.2475, N, 12158.3416, W, 0.13,309.62, 120598,, *10

Table 6: RMC Data Format

Name	Example	Units	Description
Message ID	\$GPRMC		RMC protocol header
UTS Position	161229.487		hhmmss.sss
Status	A		A=data valid or V=data not valid
Latitude	3723.2475		ddmm.mmmm
N/S Indicator	N		N=north or S=south
Longitude	12158.3416		Ddmm.mmmm
E/W Indicator	W		E=east or W=west
Speed Over Ground	0.13	Knots	
Course Over	309.62	Degrees	True
Ground			
Date	120598		Dummy
Magnetic variation		Degrees	E=east or W=west
Checksum	*10		
<CR> <LF>			End of message termination

VTG-Course Over Ground and Ground Speed

Table 7 contains the values of the following example:

\$GPVTG, 309.62, T, M, 0.13, N, 0.2, K*6E

Table 7: VTG Data Format

Name	Example	Units	Description
Message ID	\$GPVTG		VTG protocol header
Course	309.62	Degrees	Measured heading

Reference	T		True
Course		Degrees	Measured heading
Reference	M		Magnetic
Speed	0.13	Knots	Measured horizontal speed
Units	N		Knots
Speed	0.2	Km/hr	Measured horizontal speed
Units	K		Kilometer per hour
Checksum	*6E		
<CR> <LF>			End of message termination

How to Reach Us:

Skylab M&C Technology Co., Ltd.

Address: Room.801, Bldg.211, Terra Industrial Park, Futian District, Shenzhen

Phone: 86-755 8340 8160 (Sales Support)

Phone: 86-755 8340 8130 (Technical Support)

Fax: 86-755-8340 8560

E-Mail: sales@skylab.com.cn

©Copyright 2007 SkyLab M&C Co., Ltd. All Rights Reserved. Proprietary information and specifications subject to change without notice.